

Vacuum Gauges



Features/Benefits:

- Accurate monitoring – easy visual confirmation for operator, ensures consistent performance
- Effective diagnostic tool – debug and troubleshoot systems
- Economical – low cost, long life

Options:

- Dry or glycerin filled
- 3 mounting positions: bottom mount, center back mount or panel mount
- 2 dial sizes
- Materials available: Black ABS or Steel

VP20-100H with VG-150 vacuum gauge, VSXN vacuum switch with QD quick disconnect

Vaccon vacuum gauges are used in almost every area of automation including applications in pneumatics, process control, packaging, printing, medical, food and pharmaceutical.

Glycerin filled gauges extend gauge life and increase readability by dampening pulsing and vibration. All glycerin filled gauges feature a stainless steel case and bezel.

All gauges are protected with a limiting orifice to limit pressure shock. Standard dial faces have a dual scale in "Hg and Bar.

Model #	Type	Dial Size	Dual Scale Dial Range	Case	Bezel	Crystal	Bourdon Tube	Movement and Connection	Shock Protection	Accuracy				
Lower Mount														
VG-150	Dry	1.50"	0 to 30"Hg [0 to -1 bar]	Black ABS	None	Snap-on polycarbonate	Phosphor Bronze	Brass	0.5mm restrictor orifice	ASME B 40.1 Grade B (±3-2-3% of span)				
VG-150-GF	Glycerin filled			Stainless Steel	Stainless Steel	Polycarbonate								
VG-200-SS	Dry	2.00"												
VG-200-SS-GF	Glycerin filled													
Center Back Mount														
VG-150-CBM	Dry	1.50"	0 to 30"Hg [0 to -1 bar]	Black ABS	None	Snap-on polycarbonate								
Panel Mount														
VG-150-PM	Dry	1.50"	0 to 30"Hg [0 to -1 bar]	Stainless Steel	Stainless Steel	Polycarbonate								
VG-150-PMG	Glycerin filled													
VG-200-PM	Dry						2.00"							

For material availability, please consult factory.

Standard Vacuum Gauge: Bottom Mount



VG-150



VG-150-GF



VG-200-SS-GF



VG-200-SS

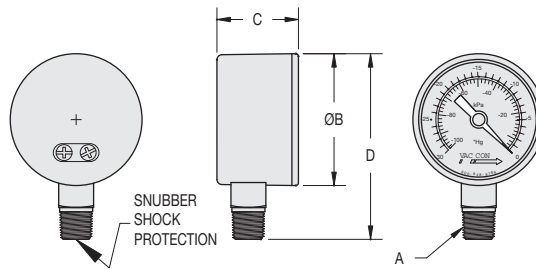

Model #	Type		A Port Connection	B - Face Dia.	C	D	Weight
VG-150	Dry	in	1/8" NPT	1.62	1.00	2.28	1.5 oz
		mm		41.1	25.4	57.9	43 g
VG-150-GF	Glycerin filled	in	1/8" NPT	1.85	1.00	2.42	2.7 oz
		mm		47.0	25.4	61.5	77 g
VG-200-SS	Dry	in	1/4" NPT	2.09	1.05	2.81	3.1 oz
		mm		53.1	26.7	71.4	88 g
VG-200-SS-GF	Glycerin filled	in	1/4" NPT	2.32	1.03	3.10	4.8 oz
		mm		58.9	26.2	78.7	136 g

Vacuum Gauge: Center Back Mount



VG-150-CBM

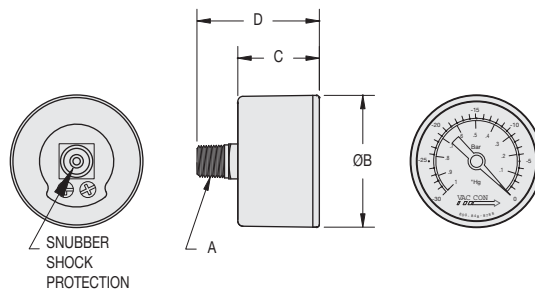

Model #	Type		A Port Connection	B - Face Dia.	C	D	Weight
VG-150-CBM	Dry	in.	1/8" NPT	1.62	1.00	1.50	1.6 oz
		mm		41.1	25.4	38.1	45 g

Vacuum Gauge: Panel Mount



VG-150-PM/VG-200-PM



VG-150-PMG

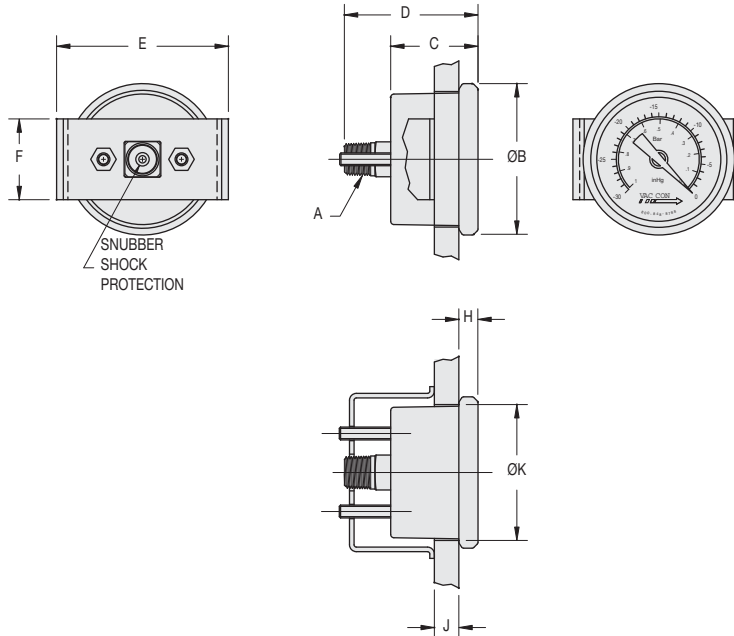

Model #	Type		A Port Connection	B - Face Dia.	C	D	E	F	H	J - Max. Panel Thickness	K - Panel Cutout +/- .03	Weight
VG-150-PM	Dry	in.	1/8" NPT	1.85	1.07	1.64	2.11	0.99	0.24	0.30	1.67	3.3 oz
		mm		47.0	27.2	41.7	53.6	25.1	6.1	7.6	42.3	94 g
VG-150-PMG	Glycerin filled	in.	1/8" NPT	1.85	1.07	1.90	2.38	1.02	0.24	0.80	1.67	3.6 oz
		mm		47.0	27.2	48.3	60.5	25.9	6.1	20.3	42.3	102 g
VG-200-PM	Dry	in.	1/4" NPT	2.32	1.03	1.60	2.81	0.99	0.20	0.10	2.07	4.7 oz
		mm		58.9	26.2	40.6	71.4	25.1	5.1	2.5	52.6	133 g

How to Specify:

Gauges should be ordered by model number as a separate line item as they are individually packaged for protection during shipping.