



MODEL 721F

CLASS 250 GLOBE VALVE

OUTSIDE SCREW & YOKE

Job Name:	Contractor:
Job Location:	P.O. Number:
Engineer:	Representative:
Tag:	Wholesale Distributor:

Description

The Apollo Model 721F Flanged Cast Iron Globe valve provides efficient throttling capabilities. The Apollo Globe valve can reliably be installed in most plumbing and heating systems (or building service piping).

Features

- Compatible with ANSI 250# & 300# Flanges
- Full Port
- Bronze Mounted Seat Rings
- Positive Shut-off
- Throttling capabilities
- Adjustable Graphite Stem Packing
- Outside Screw & Yoke
- Flanged Connection
- Bolted Bonnet
- Rugged Iron Hand Wheel
- Back Seat Protection



Standards

- MSS SP-85, "Gray Iron Globe & Angle Valves Flanged and Threaded"
- ASME B16.10, "Face-to-Face and End-to-End Dimensions of Valves"

Performance Rating

Saturated Steam: 250 psi (17.2 Bar) to 406°F(207°C)

Cold Working Pressure: 500 psi (34.5 Bar) at 100°F

Temperature Range: -20°F to 406°F

Order Information

SIZE	PART NUMBER
□ 2"	6GB218B1
□ 2.5"	6GB219B1
□ 3"	6GB210B1
□ 4"	6GB21AB1
□ 6"	6GB21CB1
□ 8"	6GB21EB1

Material Specifications

NO.	PART	MATERIAL
1	BODY	CAST IRON (ASTM A126 CL B)
2	SEAT RING	CAST BRONZE (ASTM B62)
3	GUIDE SPINDLE	BRASS (ASTM B16)
4	DISC SEAL RING	CAST BRONZE (ASTM B62)
5	DISC	CAST IRON (ASTM A126 CL B)
6	STEM	BRASS (ASTM B16)
7	CHECK SCREW	CARBON STEEL (ASTM A307 B)
8	DISC COVER	CARBON STEEL (ASTM A307 B)
9	BONNET GASKET	GRAPHITE
10	BACK SEAT BUSHING	BRASS (ASTM B16)
11	STUD	CARBON STEEL (ASTM A307 B)
12	NUT	CARBON STEEL (ASTM A307 B)
13	PACKING	GRAPHITE
14	PACKING GLAND	BRASS (ASTM B16)
15	GLAND FOLLOWER	DUCTILE IRON (ASTM A536 65-45-12)
16	SQUARE HEAD BOLT	CARBON STEEL (ASTM A307 B)
17	NUT	CARBON STEEL (ASTM A307 B)
18	BONNET	CAST IRON (ASTM A126 CL B)
19	STEM NUT	BRASS (ASTM B16)
20	SCREW	CARBON STEEL (ASTM A307 B)
21	HANDWHEEL	CAST IRON (ASTM A126 CL B)
22	WASHER	CARBON STEEL (ASTM A307 B)
23	NUT	CARBON STEEL (ASTM A307 B)

Conbraco Industries, Inc. 701 Matthews Mint Hill Rd. Matthews NC 28105 USA ; www.apollovalves.com ; 704-841-6000

Conbraco Industries can accept no responsibility for possible errors in this document and reserves the right to alter its product design or construction without notice and without incurring any obligation to make such changes on Conbraco products previously or subsequently sold. All product specifications are approximate and are provided for reference only.



MODEL 721F

CLASS 250 GLOBE VALVE

OUTSIDE SCREW & YOKE

Job Name:	Contractor:
Job Location:	P.O. Number:
Engineer:	Representative:
Tag:	Wholesale Distributor:

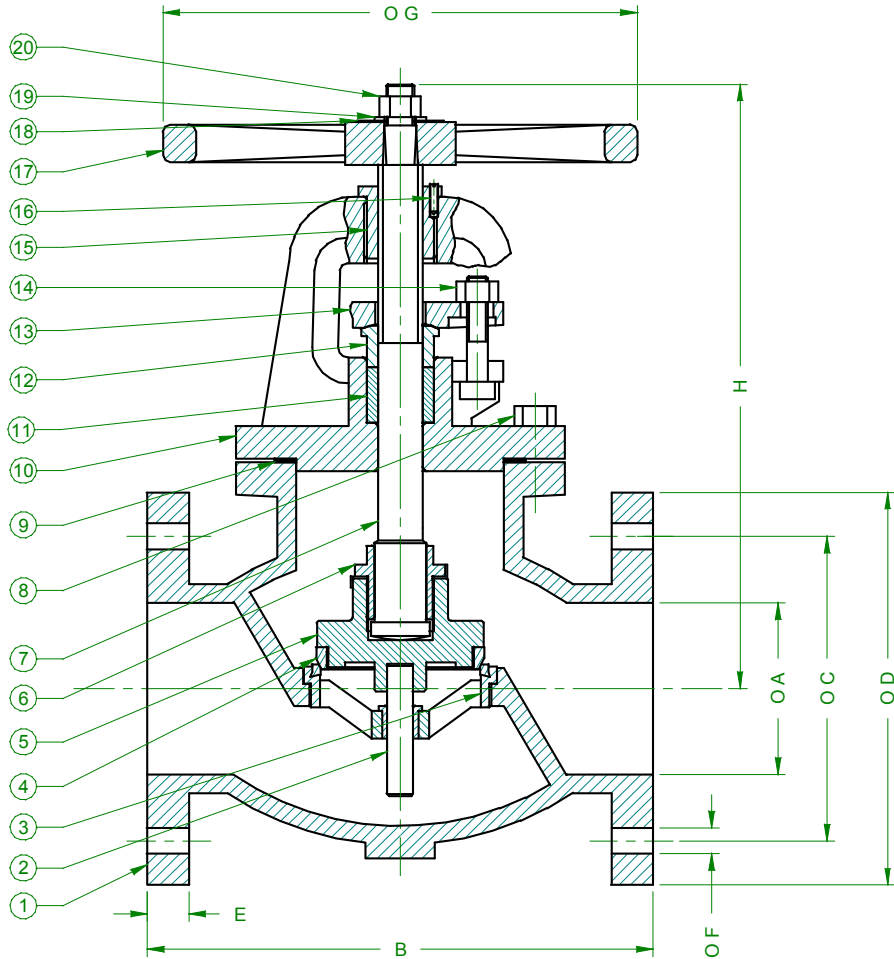

SIZE	A	B	C	D	E	F	G	H (OPEN)	WT(LBS)
2"	2.00	10.50	5.00	6.50	0.88	0.75	7.00	14.17	40.8
2.5"	2.50	11.50	5.87	7.50	1.00	0.88	7.00	15.75	52.9
3"	3.00	12.50	6.61	8.25	1.13	0.88	8.00	16.93	70.5
4"	4.00	14.00	7.87	10.00	1.25	0.88	10.00	18.90	99.2
5"	5.00	15.75	9.25	11.00	1.38	0.88	12.00	20.87	136.7
6"	6.00	17.50	10.63	12.50	1.44	0.88	12.00	23.62	202.8
8"	8.00	21.00	13.00	15.00	1.63	1.00	14.00	27.56	332.9

Conbraco Industries, Inc. 701 Matthews Mint Hill Rd. Matthews NC 28105 USA ; www.apollovalves.com ; 704-841-6000

Conbraco Industries can accept no responsibility for possible errors in this document and reserves the right to alter its product design or construction without notice and without incurring any obligation to make such changes on Conbraco products previously or subsequently sold. All product specifications are approximate and are provided for reference only.



MODEL 721F

CLASS 250 GLOBE VALVE

OUTSIDE SCREW & YOKE

Job Name:	Contractor:
Job Location:	P.O. Number:
Engineer:	Representative:
Tag:	Wholesale Distributor:

Conbraco Industries, Inc. 701 Matthews Mint Hill Rd. Matthews NC 28105 USA ; www.apollovalves.com ; 704-841-6000

Conbraco Industries can accept no responsibility for possible errors in this document and reserves the right to alter its product design or construction without notice and without incurring any obligation to make such changes on Conbraco products previously or subsequently sold. All product specifications are approximate and are provided for reference only.