



MODEL 620F

CLASS 250 GATE VALVE

NON-RISING STEM

Job Name:	Contractor:
Job Location:	P.O. Number:
Engineer:	Representative:
Tag:	Wholesale Distributor:

Description

The Apollo Model 620F Flanged Cast Iron Gate valve provides full flow capabilities. The Apollo Gate valve can reliably be installed in most plumbing and heating systems (or building service piping).

Features

- Compatible with ANSI 250# & 300# Flanges
- Full Port
- Bronze Mounted Seat Rings
- Solid Wedge
- Adjustable Graphite Stem Packing
- Non-Rising Stem
- Flanged Connection
- Bolted Bonnet
- Rugged Iron Hand Wheel
- Back Seat Protection



Standards

- MSS SP-70, "Gray Iron Gate Valves Flanged and Threaded"
- ASME B16.10, "Face-to-Face and End-to-End Dimensions of Valves"

Performance Rating

Saturated Steam: 250 psi (17.2 Bar) to 406°F(207°C)

Cold Working Pressure: 500 psi (34.5 Bar) at 100°F

Temperature Range: -20°F to 406°F

Order Information

SIZE	PART NUMBER
□ 2"	6GA208B1
□ 2.5"	6GA209B1
□ 3"	6GA200B1
□ 4"	6GA20AB1
□ 5"	6GA20BB1
□ 6"	6GA20CB1
□ 8"	6GA20EB1
□ 10"	6GA20GB1
□ 12"	6GA20HB1

Material Specifications

NO.	PART	MATERIAL
1	BODY	CAST IRON (ASTM A 126 CL B)
2	SEAT RINGS	CAST BRONZE (ASTM B62)
3	WEDGE FACE RINGS	CAST BRONZE (ASTM B62)
4	WEDGE	CAST IRON (ASTM A 126 CL B)
5	WEDGE NUT	CAST BRONZE (ASTM B62)
6	STEM	BRASS (ASTM B16)
7	BODY GASKET	GRAPHITE
8	BOLTS	CARBON STEEL (ASTM A307 B)
9	NUTS	CARBON STEEL (ASTM A307 B)
10	BONNET	CAST IRON (ASTM A 126 CL B)
11	GLAND FOLLOWER BOLTS	CARBON STEEL (ASTM A307 B)
12	STUFFING BOX GASKETS	GRAPHITE
13	STUFFING BOX	CAST IRON (ASTM A 126 CL B)
14	PACKING	GRAPHITE
15	GLAND FOLLOWER	DUCTILE IRON (ASTM A536 65-45-12)
16	PACKING GLAND	CAST BRONZE (ASTM B584)
17	HANDWHEEL	CAST IRON (ASTM A 126 CL B)
18	NAMEPLATE	ALUMINUM
19	WASHER	CARBON STEEL (ASTM A307 B)
20	HANDWHEEL NUT	DUCTILE IRON (ASTM A536 65-45-12)

Conbraco Industries, Inc. 701 Matthews Mint Hill Rd. Matthews NC 28105 USA ; www.apollovalves.com ; 704-841-6000

Conbraco Industries can accept no responsibility for possible errors in this document and reserves the right to alter its product design or construction without notice and without incurring any obligation to make such changes on Conbraco products previously or subsequently sold. All product specifications are approximate and are provided for reference only.



MODEL 620F

CLASS 250 GATE VALVE

NON-RISING STEM

Job Name:	Contractor:
Job Location:	P.O. Number:
Engineer:	Representative:
Tag:	Wholesale Distributor:

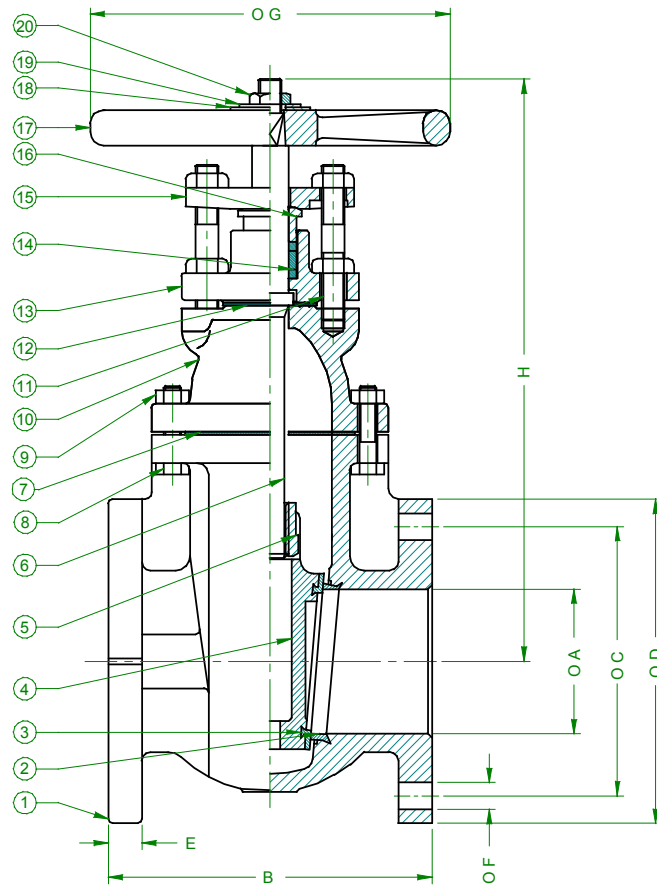

SIZE	A	B	C	D	E	F	G	H(OPEN)	WT(LBS)
2"	2.00	8.50	5.00	6.50	0.88	0.75	7	11.28	42
2.5"	2.50	9.50	5.88	7.50	1.00	0.88	7	12.72	55
3"	3.00	11.12	6.62	8.25	1.12	0.88	8	13.31	66
4"	4.00	12.00	7.88	10.00	1.25	0.88	10	16.18	115
5"	5.00	15.00	9.25	11.00	1.38	0.88	12	19.80	161
6"	6.00	15.88	10.62	12.50	1.44	0.88	12	22.00	205
8"	8.00	16.50	13.00	15.00	1.62	1.00	14	25.59	278
10"	10.00	18.00	15.25	17.50	1.88	1.12	16	30.31	456
12"	12.00	19.75	17.75	20.50	2.00	1.25	18	33.90	633

Conbraco Industries, Inc. 701 Matthews Mint Hill Rd. Matthews NC 28105 USA ; www.apollovalves.com ; 704-841-6000

Conbraco Industries can accept no responsibility for possible errors in this document and reserves the right to alter its product design or construction without notice and without incurring any obligation to make such changes on Conbraco products previously or subsequently sold. All product specifications are approximate and are provided for reference only.