



**4S Series
4SG Series**

Installation, Operation, and Maintenance Manual



Double Check Valve (DC)

Backflow Preventers

2 1/2" – 10"

&

Double Check Detector Assemblies (DCDA)

2 1/2" – 10"

TABLE OF CONTENTS

Double Check Valve Backflow Preventer 2 1/2" – 10"

Section	Page
I. Description and Operation	2
II. Installation.....	2
III. Trouble Shooting Guide.....	3
IV. Maintenance Instructions 2 1/2" – 10" DC.....	3
V. Maintenance Instructions 8" & 10" DC.....	3
VI. Testing Procedure DC.....	4-5

Double Check Detector Assembly (DCDA) 2 1/2"-10"

Section	Page
I. Description and Operation.....	6
II. Installation.....	6
III. Testing Procedure.....	7
IV. Trouble Shooting Guide.....	7

Part Lists

2 1/2" – 6" DC.....	8
8" & 10" DC.....	9,10
2 1/2" – 6" DCDA.....	11,12
8" & 10" DCDA.....	13,14
1/2" By-pass DC.....	15
Notes.....	16

Double Check Backflow Preventer (DC)

I. DESCRIPTION AND OPERATION

This maintenance manual details testing, maintenance, operation, and installation of Apollo's double check and double check detector backflow preventers. Two models are included: the 4S Series (flanged body) and the 4SG Series (grooved body).

The Double Check Valve (DC) device consists of two independently acting, spring loaded check valves. Two resilient seated shut-off valves and four test cocks complete the assembly.

Each check is designed to maintain a minimum of 1 psi across the valve during normal operation. If at any time the pressure downstream of the device increases above the supply pressure, both check valves will close to prevent any backflow from occurring.

The various styles and sizes of Double Check Valves are illustrated in Figures 1 and 2.

II. INSTALLATION

- The DC must be installed in an accessible location to facilitate periodic field testing and maintenance.
- Flush all upstream piping thoroughly to remove foreign matter prior to installing the device.
- The device may be installed in the horizontal or vertical flow-up position. Adequate clearance should be provided for ease of maintenance.
- When shut-off valves are provided separately, they should be installed with a test cock on the upstream side of the inlet shut-off valve.
- After installing the assembly and with downstream or #2 shut-off valve closed, pressurize the device and bleed air through test cock #4. Then open shut-off valve.

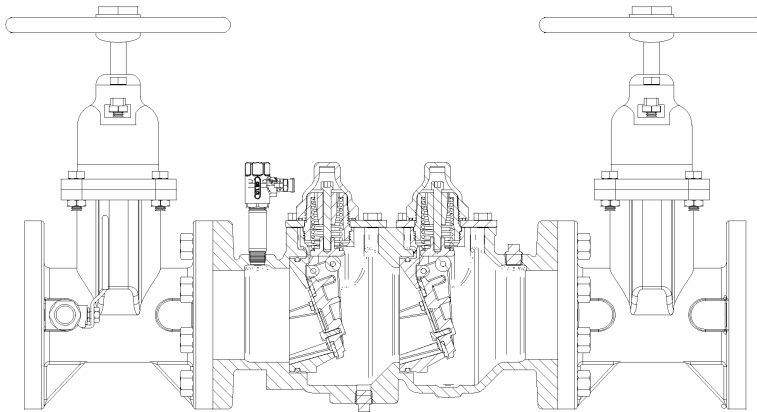

FIGURE 1
4S-100 SERIES – “MODEL DC”
(flanged body)

(NO FLOW CONDITION)

(Flanged x Flanged NRS
shut-off valves shown)

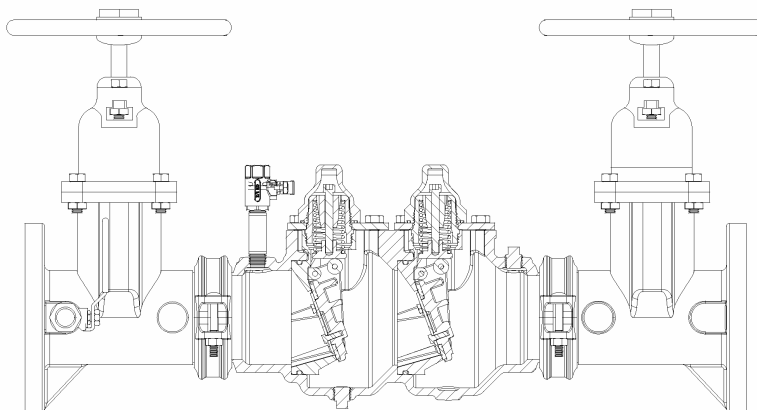

FIGURE 2
4SG-100 SERIES
(grooved body)

(NO FLOW CONDITION)

(Flanged x Grooved NRS
shut-off valves shown)

III. TROUBLE SHOOTING GUIDE

SYMPTOM	CAUSE	CORRECTIVE ACTION
1. Check valve fails to hold 1 psid.	<p>a. Shut-off valve not closed completely.</p> <p>b. Check valve fouled with debris.</p>	<p>a. Close #2 shut-off valve or inspect for possible through leakage.</p> <p>b. Inspect and clean seat disc and seat.</p>

IV. MAINTENANCE INSTRUCTIONS 2 1/2" – 6"

A. Disassembly – Check Valves

1. Close #2 shut-off valve, then close #1 shut-off valve.
2. Bleed pressure from the assembly by opening #2, #3 and #4 test cocks.
3. Unscrew black plastic cap. Remove cover bolts, cover and gasket. Pry check assembly toward outlet to loosen check from its o-ring bore.
4. Remove complete check assembly from body.
5. Unscrew and remove spring assembly from top of check assembly by placing a wrench on the flats provided. **DO NOT REMOVE THE SOCKET HEAD BOLT.** Tension will be released from the check at this point.

WARNING:

The check valve spring is held in compression by the retainer bolt. This assembly should not be disassembled as serious injury could occur. The spring and holder are sold as a pre-loaded assembly (See Page 8).

6. To remove the seat disc, remove the seat disc retaining screws and remove retaining plate. Remove disc.

B. Inspection

1. All parts should be carefully inspected for any damage or excessive wear and thoroughly rinsed in clean water prior to reassembly. Replace worn parts as necessary.

C. Assembly – Check Valves

1. Install seat disc in swing arm and secure with retaining plate and applicable screws.

NOTE:

Due to the symmetry of the disc, the old disc may be turned over to obtain an effective seal.

2. Install the spring assembly into seat housing, making sure assembly is tight.
3. Install check valve assembly into body and push tight into place (toward inlet). To aid installation, liberally apply a non-toxic grease to o-ring surface. A pry-bar may be needed to aid in seating check assembly into o-ring bore. The test cock immediately upstream must be open to release the air in the chamber.
4. Replace gasket, cover plate, and bolts. Tighten bolts evenly. Replace spring cap. **DO NOT OVER TIGHTEN CAP.**

V. MAINTENANCE INSTRUCTIONS 8" & 10"

A. Disassembly – Check Valves

1. Close #2 shut-off valve, then close #1 shut-off Valve.
2. Bleed pressure from the assembly by opening #2, #3, and #4 test cocks.
3. Remove cover bolts, cover, spring assembly, and gasket. Pry check assembly toward outlet to loosen check from its o-ring bore.
4. Remove check assembly from body.
5. To remove the seat disc, remove the seat disc retaining screws and remove retaining plate. Remove disc.

WARNING:

Do not disassemble the spring module as serious injury may occur.

6. All parts should be carefully inspected for any damage or excessive wear and thoroughly rinsed in clean water prior to reassembly. Replace worn parts as necessary.

B. Assembly – Check Valves

1. Install seat disc in seal retainer and secure with retaining plate and applicable screws. Due to the symmetry of the disc, the old disc may be turned over to obtain an effective seal.
2. Install check valve assembly into body and push tight into place (toward inlet). To aid installation, liberally apply a non-toxic grease to o-ring surface. A pry-bar will be needed to aid in seating check assembly into the o-ring bore. The testcock immediately upstream must be open to release the air in the chamber.
3. Replace spring assembly, gasket, and cover, making sure to place cam end of spring assembly on both cam rollers of the check assembly. The cover places approximately 1/4" of preload on the spring assembly.

VI. TESTING PROCEDURES

NOTE:

IT IS IMPORTANT THAT THE DC DEVICE BE TESTED PERIODICALLY IN COMPLIANCE WITH LOCAL CODES, BUT AT LEAST ONCE A YEAR OR MORE, AS SERVICE CONDITIONS WARRANT.

NOTE:

Test set-up is illustrated in Figure 3.

EQUIPMENT REQUIRED:

Differential pressure gauge type test kit such as Apollo Valves Model No. 40-200-TKU or 40-200-TK5U.

NOTE:

For all testing, the gauge and open ends of hoses not being used must be held at the same level as the assembly being tested.

TEST NO. 1:

Purpose:

To determine the static pressure drop across check valve No. 1.

Requirement:

The static pressure drop across check valve No.1 shall be at least 1 psid.

PROCEDURE:

1. To eliminate foreign material, flush all four test cocks, one at a time.
2. Open test valves No.1 and No.2 on the gauge and close test valve No.3. Attach "high" side hose to test cock No.2.
3. Bleed all air from hose and gauge by slowly opening test cock No.2. Then slowly close test valve No.2.
4. Close the outlet shut-off valve. Then close the inlet shut-off valve.
5. Slowly open test cock No.3. After the gauge reading stabilizes and water stops running out of test cock No.3, the static pressure drop across the check valve is indicated by the gauge and is recorded as such.

NOTE: If water continues to discharge from test cock No.3 then a leaky shut-off valve is evident and should be repaired or by-passed before testing continues. If the water recedes from the test cock opening then move the gauge to a point level with the centerline of the check seat area and record the gauge reading as the static pressure differential across check No.1.

TEST NO. 2

Purpose:

To determine the static pressure drop across check valve No.2.

Requirement:

The static pressure drop across check valve No.2 shall be at least 1 psid.

PROCEDURE:

1. Open test valves No.1 and No.2 on the gauge and close test valve No.3. Attach "high" side hose to test cock No.3.
2. Bleed all air from hose and gauge by slowly opening test cock No.3. Then slowly close test valve No.2.
3. Close the outlet shut-off valve. Then close the inlet shut-off valve.
4. Slowly open test cock No.4. After the gauge reading stabilizes and water stops running out of test cock No.4, the static pressure drop across the check valve is indicated by the gauge and is recorded as such.

NOTE: If water continues to discharge from test cock No.4 then a leaky shut-off valve is evident and should be repaired or by-passed before testing continues. If the water recedes from the test cock opening then move the gauge to a point level with the centerline of the check seat area and record the gauge reading as the static pressure differential across check No.2.

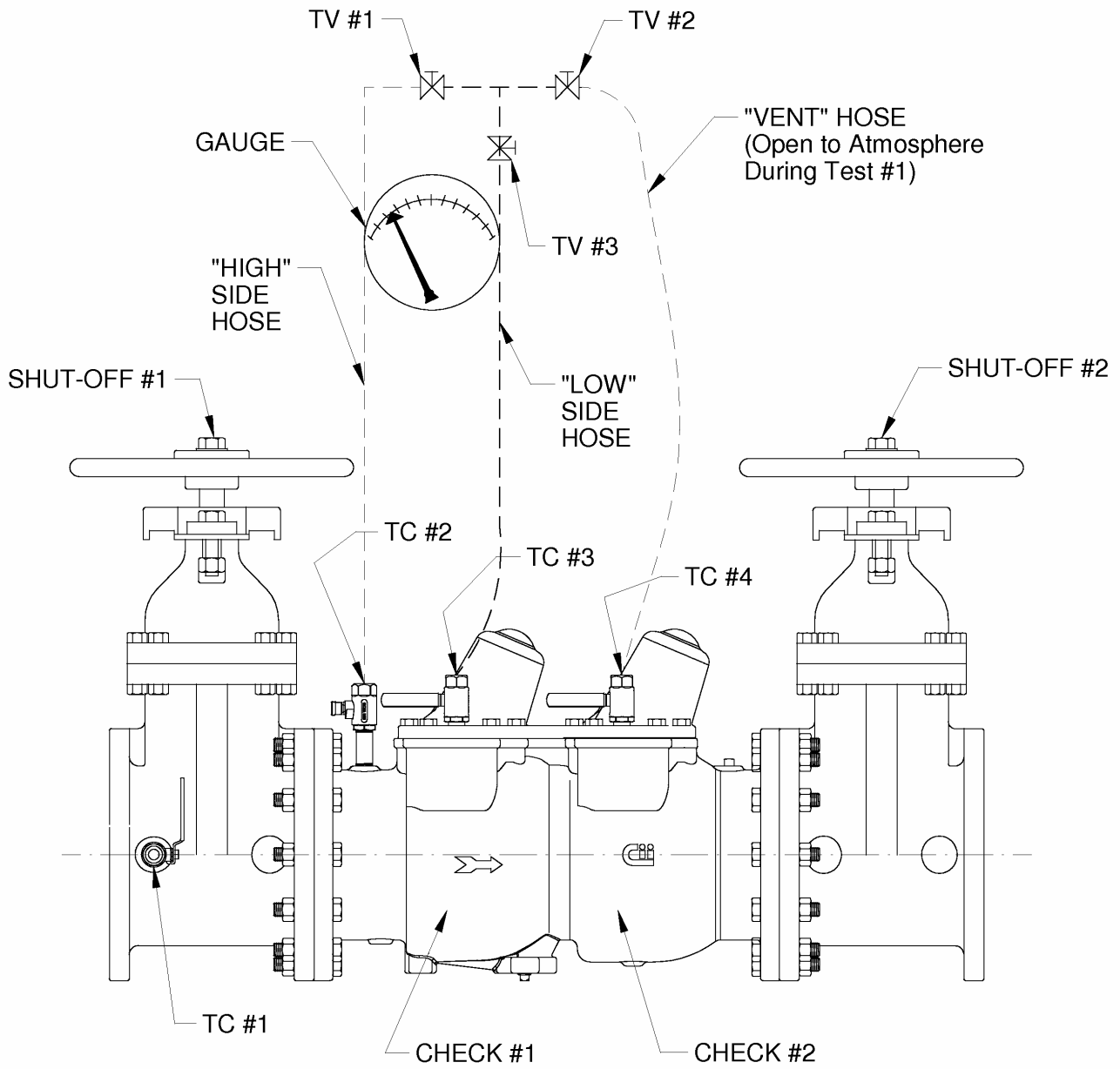

FIGURE 3

LEGEND

TV (TEST VALVE)
 TC (TEST COCK)

Double Check Detector Assembly (DCDA)

I. DESCRIPTION AND OPERATION

The Double Check Detector Assembly (DCDA) consists of a mainline DC incorporating two spring loaded check valves and a by-pass assembly consisting of an approved DC assembly and a water meter. Each device is equipped with test cocks for periodic field testing and is normally supplied with inlet and outlet shut-off valves. NOTE: UL and FM installations must include indicating type shut-off valves.

During no flow conditions, the mainline and by-pass check valves will remain closed. If there is a low flow demand (up to a minimum of 3 gpm) of water downstream, the flow is routed through the water meter to monitor such consumption. If the downstream pressure increases above the supply pressure or there is a reduction in the inlet pressure, the mainline and by-pass check valves will close to prevent backflow.

II. INSTALLATION

- The DCDA must be installed in an accessible location to facilitate periodic field testing and maintenance.
- Flush all upstream piping thoroughly to remove foreign matter prior to installing the device.
- The device may be installed in the horizontal or vertical flow-up position. A clearance of 12" to 30" between the lower most portion of the device and flood grade or floor should be provided for ease of maintenance
- When shut-off valves are provided separately, they should be installed with a test cock on the upstream side of the inlet shut-off valve.
- After installing the assembly and with downstream or #2 shut-off valve closed, pressurize the device and bleed air through test cock #4. Then open #2 shut-off valve.

OTHER INSTALLATION TIPS

- Installing this device in a pit requires consideration for future maintenance and repair. Along with necessary clearances, there must be adequate drainage within the pit to deter potential accumulation of standing water. Also, check with local codes and / or inspectors prior to making such installations.
- Do not install in areas subject to freezing.
- As in any piping system, provisions should be made to minimize water hammer and pressure rise due to thermal expansion, as these conditions can create damaging and dangerously high internal pressures.

MAINTENANCE INSTRUCTIONS

MAINLINE: REFER TO PAGE 3 OF THIS MANUAL

BY-PASS DC:

Disassembly:

- Close by-pass inlet and outlet shut-off valves (Figure 5).
- Bleed pressure from the by-pass assembly by opening test cock No. 2,3 and 4.
- Unscrew and remove bronze cap.
- Remove stainless steel spacer using lifting tab.
- Remove first check module by pulling outward with fingers (A small screwdriver may help aid removal). Be sure test cock No.2 is open to prevent hydraulic lock. Generally, the first check o-ring will remain in the bore.
- Remove second check assembly by sliding the assembly out of its bore (A small flat screwdriver placed in the groove provided will aid removal). Be sure test cock No.4 is open as to prevent hydraulic lock.

Inspection:

- All parts should be carefully inspected for any damage or excessive wear and thoroughly rinsed in clean water prior to reassembly.
- Replace all worn parts as necessary.

NOTE:

Check valve modules are not user serviceable. In the event of check failure, replacement modules are sold individually.

Assembly:

- Replace check modules, second check first then first check. Make sure first check o-ring is installed. (**Tip:** Push o-ring to the bottom of the bore before installing check module.) Press check module into bore. A thin coat of synthetic based lubricant on o-ring will aid insertion.
- Replace stainless steel spacer.
- Apply a thin coat of synthetic based lubricant on cap o-ring. Replace cap.

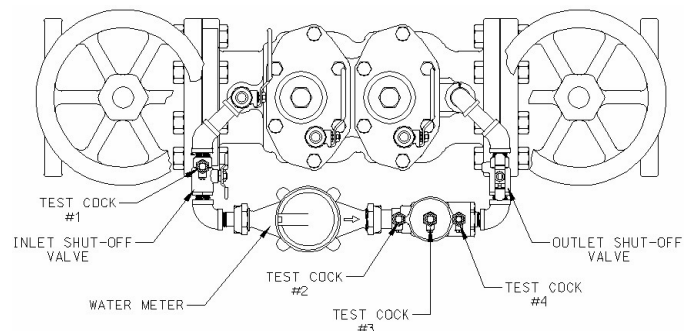

FIGURE 4

III. TESTING PROCEDURE DCDA

It is important that this DCDA device be tested periodically in compliance with local codes, but at least once a year or more as service conditions warrant.

EQUIPMENT REQUIRED:

Test Kit such as Apollo Valves Model No. 40-200-TKU or 40-200-TK5U.

NOTE: DURING TESTING, THE DIFFERENTIAL PRESSURE GAUGE AND ALL HOSES NOT BEING USED MUST BE HELD AT THE SAME LEVEL AS THE ASSEMBLY BEING TESTED.

MAINLINE TEST

Refer to pages 4 – 5 of this manual for Mainline test instructions.

Shut-off valves on by-pass must be closed for this test.

BY-PASS TEST

Testing procedures for by-pass DC are similar to the mainline DC except as follows:

1. For all testing the inlet by-pass shut-off valve remains open.
2. Flush water through test cocks No. 5, 6, 7 and 8 to eliminate foreign material.
3. To test check valve No. 1 connect the “high” side hose to test cock No. 6. To test check valve No. 2 connect the “high” side hose to test cock No. 7.
4. To pressurize by-pass line, close the inlet shut-off valve on the mainline and by-pass line.

RESTORE OPERATION:

Close all test cocks, open all test valves and remove all test equipment. Slowly open the inlet shut-off valve on the mainline. Then slowly open the outlet shut-off valve on the mainline. Open the shut-off valves on the by-pass.

NOTE:

Refer to troubleshooting guide to resolve any problems encountered during field testing.

IV. TROUBLESHOOTING GUIDE

SYMPTOM	CAUSE	CORRECTIVE ACTION
Check valve fails to hold 1 psid.	A. Shut-off valve not closed completely. B. Check valve fouled with debris.	A. Close outlet shut-off valve or inspect for possible through leakage. B. Inspect and clean seat disc and seat.

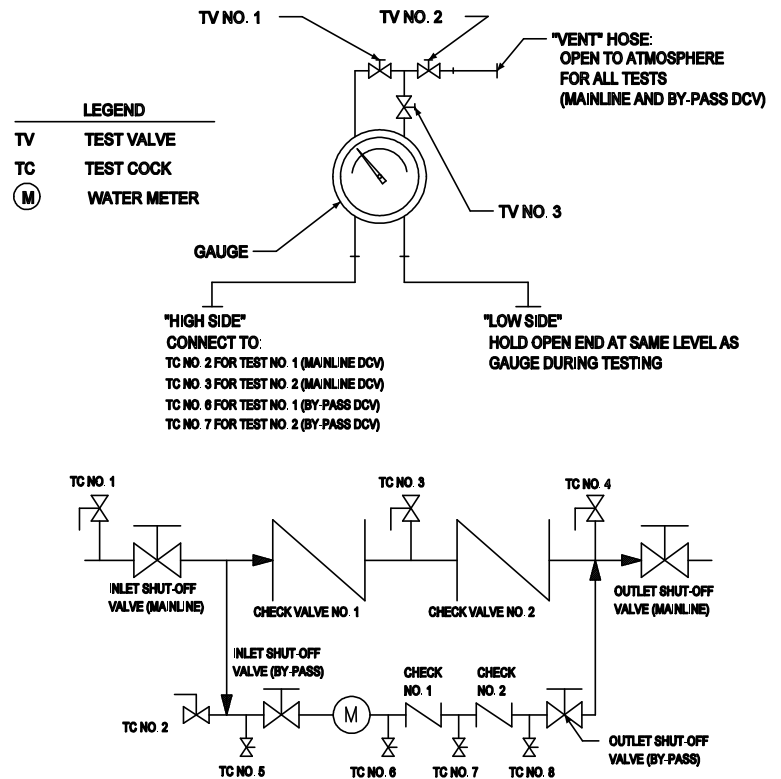

FIGURE 5

Double Check Backflow Preventer 2 1/2" – 6"

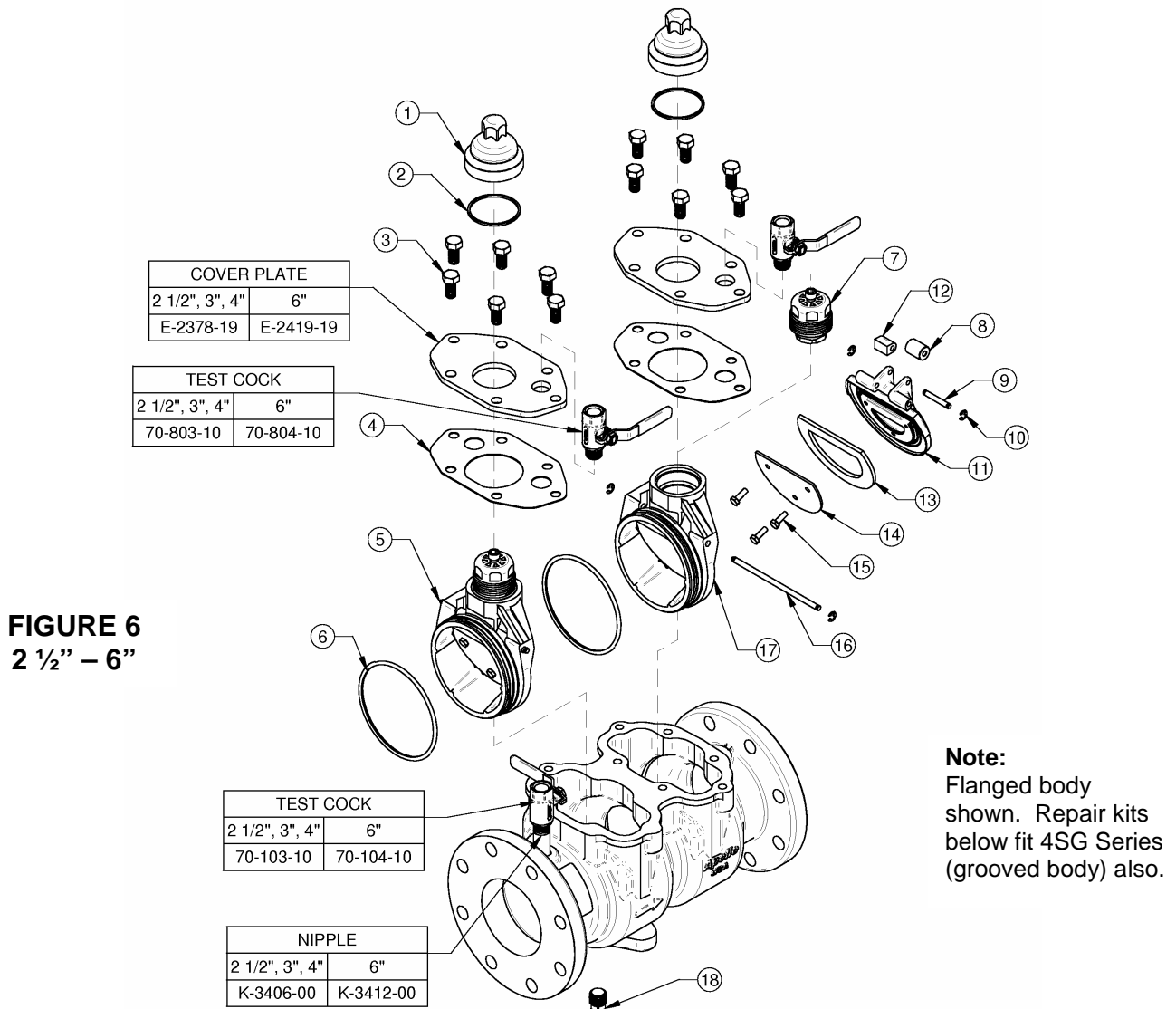
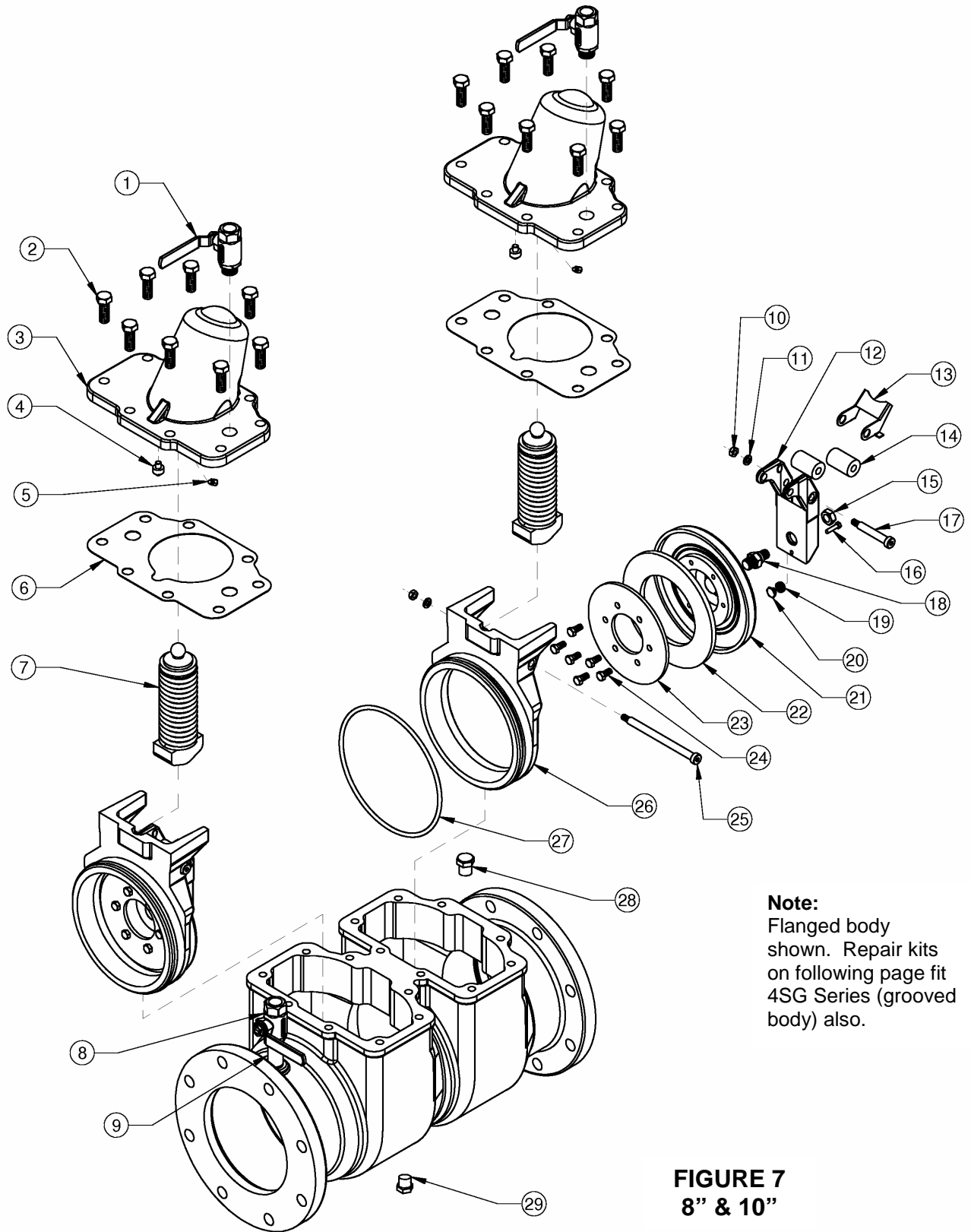

FIGURE 6
2 1/2" – 6"

ITEM #	DESCRIPTION	QTY.	PART #	ITEM #	DESCRIPTION	QTY.	PART #
1	Spring Cap	2	S-4877-00	12	Hinge Bushing	2	D-3685-00
2	O-Ring	2	D-3506-00	13	Seat Disc	2	D-3504-00
3	Cover Bolt	12	B-2083-00	14	Disc Plate	2	E-2379-00
4	Gasket	2	D-3505-00	15	Disc Ret. Bolt	6	B-1793-00
5	Check Assembly	2	W-7590-05	16	Hinge Pin	2	I-5868-06
6	O-Ring	2	D-3507-00	17	Seat Housing	2	F-3090-00
7	Spring Assembly	2	W-8393-00	18	Plug	2	K-3008-00
8	Roller	2	I-5866-00				
9	Roller Pin	2	I-5867-06				
10	"E" Clip	4	I-3144-00				
11	Swing Arm	2	G-3769-00				

REPAIR KITS FOR 2 1/2" – 6"

Check Valve Repair Kit (Includes 1 each of items 2, 4, and 5).....4S-009-01
 Rubber Repair Kit (includes 1 each of items 2, 4, 6, 12, and 13).....4S-009-02



Note:
 Flanged body
 shown. Repair kits
 on following page fit
 4SG Series (grooved
 body) also.

FIGURE 7
8" & 10"

Double Check Backflow Preventer 8" & 10" DC

ITEM #	DESCRIPTION	QUANTITY	PART #
1	¾" Test Cock	2	70-804-10
2	Cap Bolt	16	B-1800-00
3	Cover	2	Q-5624-19
4	Pilot Pin	2	I-6411-06
5	Cam Bumper	2	I-6412-06
6	Gasket	2	D-3964-00
7	Spring Ass'y	2	W-4373-05
8	¾" Test Cock	1	70-104-10
9	¾" Nipple	1	K-3412-00
10	Nut	2	C-2039-00
11	Lock Washer	2	E-2276-00
12	Swing Arm	1	F-3235-05
13	Positioner	1	I-6441-00
14	Cam Roller	2	I-6410-00
15	Stem Nut	2	C-2040-00
16	Compensator Bolt	2	B-2183-00
17	Roller Pin	2	B-2518-00
18	Check Stem	2	G-3980-06
19	Compensator Spring	2	A-1459-00
20	Spring Button	2	E-2497-06
21	Seal Retainer	2	F-3225-05
22	Seat Disc	2	D-3961-00
23	Disc Plate	2	E-2494-00
24	Disc Retainer Bolt	12	B-1754-00
25	Hinge Pin	2	B-2517-00
26	Seat	2	L-6137-05
27	Seat O-ring	2	D-3963-00
28	¾" Plug	1	K-3010-00
29	½" Plug	1	K-3008-00

REPAIR KITS FOR 8" & 10"

Check Valve Repair Kit (Includes items 6 and 10-27, repairs 1 check valve).....4S-00E-06
 Rubber Repair Kit (includes 1 each of items 6, 22, and 27).....4S-00E-04

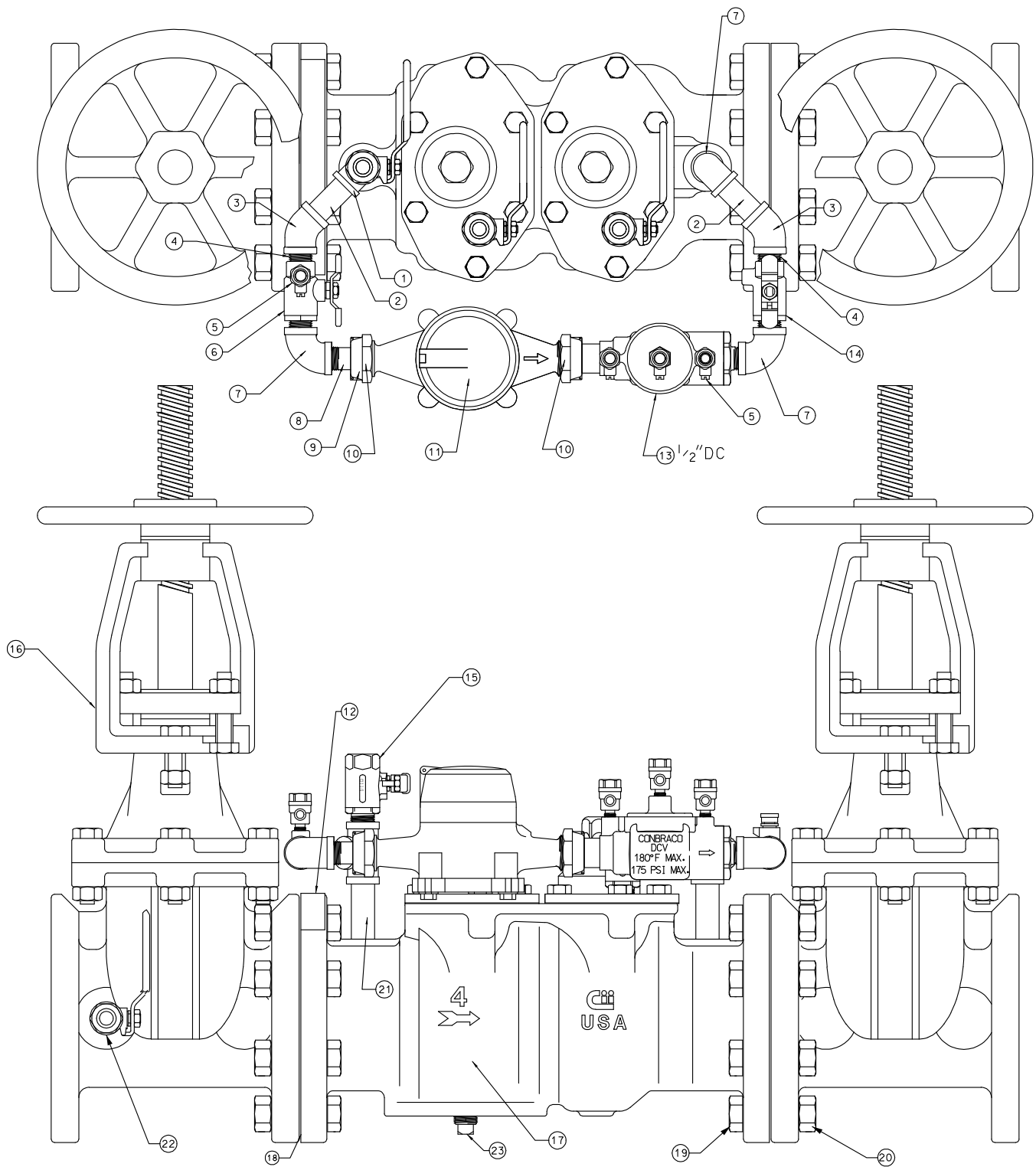

FIGURE 8
2 1/2" - 6" DCDA

Double Check Detector Assembly 2 1/2" – 6" DCDA

ITEM #	DESCRIPTION	QUANTITY	PART #
1	1/2" X 1/2" x 1/2" Tee	1	K-3571-00
2	1/2" NPT x 2" Nipple	2	K-3771-00
3	1/2" NPT x 45° Elbow	2	K-3963-00
4	1/2" NPT Close Nipple	2	K-3460-00
5	1/8" Testcock	1	78-257-01
6	1/2" Hydro Ball Valve	1	7B-803-01
7	1/2" NPT x 90° Elbow	3	K-3959-00
8	Meter Connector	1	K-3960-00
9	Swivel Nut	1	C-1844-05
10	Meter Union Washer	2	D-2610-00
11	Water Meter (Gallons)	1	W-7094-00
	Water Meter (Cubic Feet)	1	W-7062-00
13	1/2" DC (By-pass)	1	W-4321-00
14	1/2" Hydro Ball Valve (No Tap)	1	7B-803-31
15	1/2" MxF Ball Valve	3	70-803-10
16	Gate Valve	2	Consult Factory
17	Mainline DC		
18	Ring Gasket	2	Consult Factory
19	Flange Bolt		Consult Factory
20	Flange Nut		Consult Factory
21	3/4" NPT x 3" Nipple (6") W/	1	K-3406-00
22	1/2" FxF Ball Valve	1	70-103-10
23	1/2" NPT Brass Plug	1	K-3008-00

DCDA BY-PASS ASSEMBLY KITS

2 1/2" DCDA w/ meter in cubic feet.....	4S60ABPC
2 1/2" DCDA w/ meter in gallons.....	4S60ABPE
3" DCDA w/ meter in cubic feet.....	4S60ABPC
3" DCDA w/ meter in gallons.....	4S60ABPE
4" DCDA w/ meter in cubic feet.....	4S60ABPC
4" DCDA w/ meter in gallons.....	4S60ABPE
6" DCDA w/ meter in cubic feet.....	4S60CBPC
6" DCDA w/ meter in gallons.....	4S60CBPE

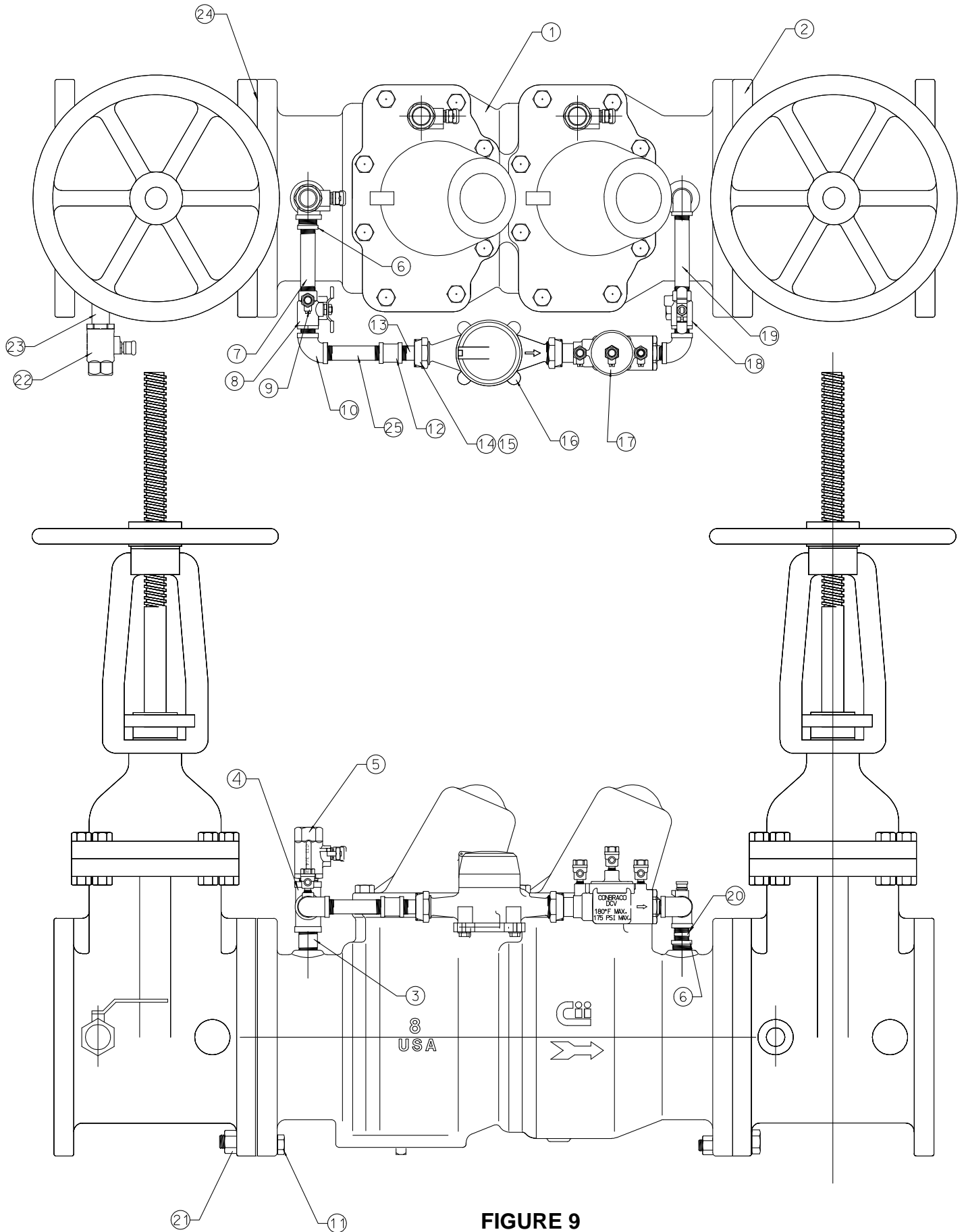

FIGURE 9
8" & 10 DCDA

Double Check Detector Assembly 8" & 10" DCDA

ITEM #	DESCRIPTION	QUANTITY	PART #
1	Mainline DC	1	
2	Gate Valve	2	Consult Factory
3	¾" NPT x 2" Nipple	1	K-3772-00
4	¾" NPT Tee	1	K-3511-00
5	¾" Testcock	1	70-804-10
6	¾" NPT x ½" NPT Reducer Bushing	2	K-3503-00
7	½" NPT x 5" Nipple	1	K-3980-00
8	½" M x F Full Port Ball Valve	1	7B-803-01
9	1/8" Testcock	1	78-257-01
10	½" NPT x 90° Elbow	3	K-3959-00
11	Flange Bolt		Consult Factory
12	½" NPT Coupling	1	K-3979-00
13	Meter Connector	1	K-3960-06
14	Meter Nut	1	C-1844-05
15	Meter Nut Washer	2	D-2610-00
16	Water Meter (GPM)		W-7094-00
	Water Meter (CU. FT)		W-7062-00
17	½" DC (By-pass)	1	W-4321-00
18	½" M x F Full Port Ball Valve (No Tap)	1	7B-803-31
19	½" NPT x 6" Nipple	1	K-3981-00
20	½" NPT Close Nipple	1	K-3460-00
21	Flange Nut		Consult Factory
22	¾" NPT Ball Valve	1	70-103-10
23	¾" NPT x 3" Nipple	1	K-3412-00
24	Flange Gasket	2	Consult Factory
25	½" NPT x 4" Nipple	1	K-3982-00

DCDA BY-PASS ASSEMBLY KITS

8" DCDA w/ meter in cubic feet.....4S60EBPC
8" DCDA w/ meter in gallons.....4S60EBPE
10" DCDA w/ meter in cubic feet.....4S60GBPC (Not available in 4SG Series)
10" DCDA w/ meter in gallons.....4S60GBPE (Not available in 4SG Series)

1/2" By-Pass DC Unit (W-4321-00)

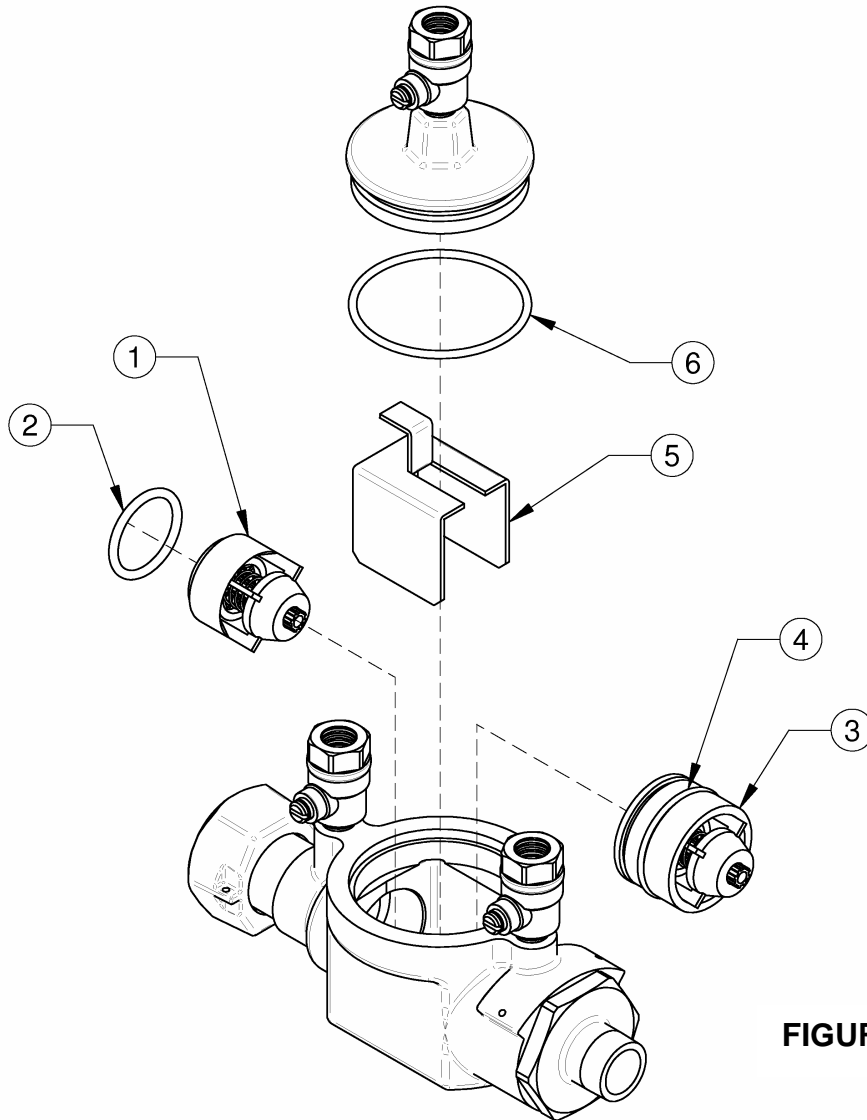

FIGURE 10

ITEM #	DESCRIPTION	QUANTITY	PART #
1	1 st Check Module	1	F-3228-00
2	1 st Check O-Ring	1	D-3885-00
3	2 nd Check Module	1	W-4302-00
4	2 nd Check O-Ring	1	D-2422-00
5	Check Spacer	1	L-6161-00
6	Cap O-Ring	1	D-2568-00

REPAIR KIT (includes 1 each of items 1, 2, 3, 4, and 6).....4S-003-01

NOTES
